



## Installation Instructions ZX835 Microwave/PIR Detector with POPIT Interface

### 1.0 Specifications

- **Input Power:** 9 to 15 VDC, 6 mA nominal (35 mA with LED on).
- **Standby Power:** There is no internal standby battery. Connect to standby power as a backup in the event primary power fails. Six (6) mA-H required for each hour of standby time needed. *Four hours minimum is required for U. L. Listed Requirements.*
- **Temperature:** The operating temperature range is -20° to +120°F (-29° to +49°C). *For U. L. Listed Requirements, the temperature range is +32° to +120°F (0° to +49°C).*
- **Microwave Frequency:** 10.525 Ghz, ±25.000 Mhz.
- **Coverage:** 35 ft. by 35 ft. (10.7 m by 10.7 m)
- **Internal Pointability:** +2° to -10° Vertical, ±10° Horizontal.
- **Tamper:** Tamper condition transmitted through the Zonex bus when the cover is removed.
- **Requirements:** Requires a compatible control panel with a POPEX module installed.
- **Options:** B328 Gimbal Mount Bracket, B335 Low Profile Swivel Mount Bracket (use of a bracket may reduce range and dead zone areas).
- **U. S. Patent Numbers:** # 4,660,024, # 4,764,755, # 5,077,548, # 5,208,567, #5,262,783, and # 5,450,062. Other patents pending.

### 2.0 Installation Considerations

- Never install the detector in an environment that causes an alarm condition in one technology. Good installations start with the LED **OFF** when there is no target motion. It should never be left to operate with the tri-color LED in a constant or intermittent green, yellow, or red condition.
- Point the unit away from outside traffic (roads/alleys). **Remember:** Microwave energy will pass through glass and most common non-metallic construction walls. Avoid installations where rotating machines (e.g. ceiling fans) are normally in operation within the coverage pattern.
- Point the unit away from glass exposed to the outdoors and objects that may change temperature rapidly. **Remember:** The PIR detector will react to objects rapidly changing temperature within its field-of-view.
- Eliminate interference from nearby outside sources.

### 3.0 Mounting

- Select a location likely to intercept an intruder moving **across** the coverage pattern. The surface should be solid and vibration free. Mounting height range is 6 to 8 ft. (1.8 to 2.4 m). **Recommended mounting height is 6.5 ft. (2 m).**
- Remove the cover. Insert a flathead screwdriver into the locking tab hole at the bottom front of the detector. Pull the cover up and forward.
- Mount the unit with the terminal block up.
- Remove the circuit board from the base. Loosen the Vertical Adjust Screw and slide the circuit board down then out.
- Break away the appropriate thin-wall wire entrance and mounting hole coverings in the base.
- Using the base as a template, mark the location of the holes on the mounting surface.
- Route wiring (unpowered) as necessary. Route to the rear of the base and through the wire entrance.
- Firmly mount the base to the mounting surface. Return the circuit board to the base and tighten the Vertical Adjust Screw.

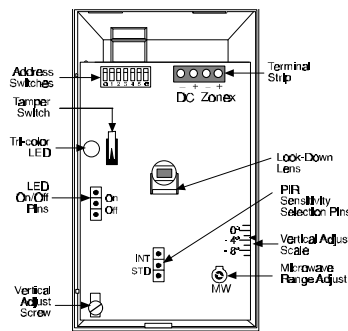

### 4.0 Programming

Program the address DIP switches as described for the control panel you are using.

**Note:** When installing the ZX835 with a D7212B1, D8112, D9112B1, D9412, or D9112; place switch number "0" in the ON position.

Recommended point type programming =

- D8112 = 6571
- D9112B1/D7212B1 = Point type 2, point response 2, no ring until restored.
- D9412/D9112 = Point type 2, point response E, no ring until restored.

### 5.0 Wiring

#### ZONEX LOOP

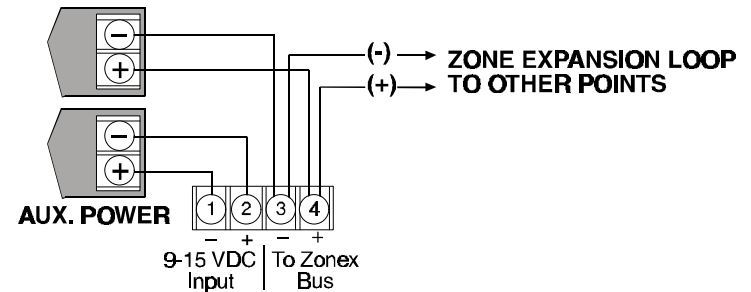

**CAUTION:** APPLY POWER AFTER ALL CONNECTIONS HAVE BEEN MADE/INSPECTED. DO NOT COIL EXCESS WIRING INSIDE DETECTOR.

**Plug the wire entrance hole with the foam plug provided after all wiring connections have been made.**

### 6.0 LED Operation

The detector uses a tri-color LED to indicate the various alarm and supervision trouble conditions that may exist. See the chart below.

LED	CAUSE
Steady red	Unit alarm
Steady yellow	Microwave Activation (walk test)
Steady green	PIR activation (walk test)
Flashing red	Warmup period after power-up
Flashing red (4 pulse sequence)	Microwave or PIR failure. Replace unit.

If the detector experiences a Microwave or PIR self-test failure, it is in need of replacement.

During walk testing, the LED will light for the first technology (microwave or PIR) and then light red to indicate a detector alarm. The LED will not indicate activation of the second technology by lighting its color.

### 7.0 Feature Selection

- **LED On/Off Pins:** The ON position allows operation of the tri-color LED. If the tri-color LED indication is not desired after setup and walk tests are completed, place the plug in the OFF position. The OFF position does not prevent the tri-color LED from indicating a supervision trouble condition.

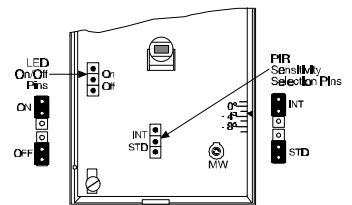

- **PIR Sensitivity Selection Pins:** The PIR response sensitivity may be selected by placing the plug across the pins marked (STD) for Standard or (INT) for Intermediate mode.

Standard Sensitivity: The recommended setting for maximum false alarm immunity. Tolerates environmental extremes on this setting.

Intermediate Sensitivity: The recommended setting for **non-pet** applications where an intruder is expected to cover only a small portion of the protected area. Tolerates normal environments on this setting. This setting will improve your intruder catch performance. (Recommended for higher mounting heights).

## 8.0 Setup and Walk Tests

Select the vertical starting angle from the chart. To adjust the vertical starting angle for the desired mounting height and range, loosen the vertical adjust screw and slide the board up, to point the angle down. Note the settings on the vertical adjust scale.

D9635T	
Mounting Height	Range
6.5 ft. (2 m)	-5°
7.0 ft. (2.1 m)	-6°
8.0 ft. (2.4 m)	-7°

**Note:** A mounting height of 6 1/2 feet and the proper vertical angle must be selected for installations containing pets. See Section 12.0.

- Place the LED plug in the ON position.
- Wait at least two minutes**, after applying power, to start walk tests.

**Note:** During the warm-up period, the tri-color LED will flash red until the unit has stabilized and has seen no movement for two seconds (approx. 1 to 2 minutes). When the LED stops flashing, the detector is ready to be tested. With no motion in the protection area, the LED should be OFF. If the LED is on, re-check the protection area for disturbances affecting the microwave (yellow) or PIR (green) technologies.

### Establishing PIR Pattern Coverage

- Turn the Microwave range adjust to minimum and replace the cover.
- Walk test **across** the pattern at its farthest edge, then several times closer to the detector. Start walking from outside of the intended protection area, and observe the tri-color LED. The edge of the pattern is determined by the first green, PIR activation of the LED (or the first red activation if the yellow microwave LED activates first).
- Walk test from the opposite direction to determine both boundaries. The center of the pattern should be pointed toward the center of the intended protection area.
- Slowly bring your arm up and into the pattern to mark the lower boundary on PIR alarm. Perform this task at 10 to 20 ft. (3.1 to 6.1 m) from the unit. Repeat from above for the upper boundary. **The center of the pattern should not be tilted upward.**

If desired coverage can not be achieved, try angling the coverage pattern up or down to assure the pattern is not aimed too high or low. For pet applications, do not adjust below recommended angle. **The angle of the PIR pattern may be vertically positioned between -10° and +2° by loosening the Vertical Adjust screw and sliding the circuit board up or down. Moving the board up will angle the pattern downward.** Tighten the screw snug when positioning is completed.

**Note:** The pattern may be moved  $\pm 10^\circ$  horizontally by moving the lens window left/right.

### Establishing Microwave Coverage

**Note:** It is important to wait 1 minute after removing/replacing the cover so the microwave portion of the detector can settle, and to wait at least 10 seconds between the following walk testing procedures.

- The tri-color LED should be OFF before walk testing.
- Walk test **across** the pattern at the intended coverage's **farthest end**. Start walking from outside the intended protection area and observe the tri-color LED. The edge of the microwave pattern is determined by the first yellow, microwave activation of the LED (or the first red activation if the green PIR LED activates first).
- If adequate range can not be reached, increase the Microwave Range Adjust **slightly**. Continue walk testing (waiting 1 minute after removing/replacing the cover) and adjusting the range until the farthest edge of desired coverage has been accurately placed.

**Do not adjust the microwave range higher than required. Doing so will enable the detector to catch movement outside of the intended coverage pattern.**

- Walk test the unit from all directions to determine all the detection pattern boundaries.

### Establishing Detector Coverage

- The tri-color LED should be OFF before walk testing.
- Walk test the unit from all directions to determine the detection boundaries. A detector alarm is signaled by the first red activation of the tri-color LED after an initial green or yellow activation.

## 9.0 Supervision Features

The supervision features function as follows:

- PIR/Microwave:** The complete circuit operation of these subsystems is tested approximately every 6 hours. If the PIR or microwave subsystem fails, a second test is performed after one hour. If the PIR or microwave subsystem fails the second test, the tri-color LED will flash red 4 times per cycle and the unit should be replaced.
- Default:** The detector will default to PIR technology protection if the microwave subsystem fails. When defaulting to PIR, the PIR signal processing will change from INT to STD sensitivity.

## 10.0 Other Information

**Maintenance:** At least once a year, the range and coverage should be verified. To ensure continual daily operation, the end user should be instructed to walk through the far end of the coverage pattern. This ensures an alarm output prior to arming the system.

**Pattern Masking:** The PIR coverage pattern may be masked using masking tape or electrical tape on the inside of the lens.

**Note:** Masking only eliminates the PIR portion of the coverage and has no effect on the microwave pattern.

## 11.0 Coverage Pattern

The protected coverage area is where the microwave and PIR patterns overlap.

An optional Look Down lens is located under the detector. This lens must be unmasked before it is operational. The Look Down lens is **not recommended** for installations containing pets or small animals. The Look Down finger is shown in black below.

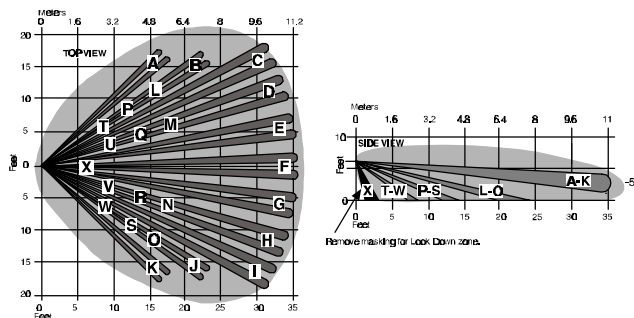

## 12.0 Special Instructions for Installations Containing Pets

The ZX835 will provide reasonable protection from nuisance alarms caused by the following sources:

- A dog up to 100 pounds (45 kg)
- Two 60 pound (27 kg) dogs
- Multiple small rodents, such as rats
- Up to 10 cats
- Random flying birds

To take full advantage of the ZX835's Signature Recognition Technology, the following guidelines should be followed:

- Mount the detector 6-1/2 ft. (2 m) high and adjust the PIR angle to -5°.
- Set the PIR sensitivity for Standard (STD).**
- Mount where the animals can not come within 6 ft. (1.8 m) of the detector by climbing on furniture, boxes or other objects.
- Do not remove the Look Down lens mask.
- Don't aim the detector at stairways the animals can climb on.
- Adjust the microwave range for the minimum acceptable coverage for the room in which the detector is installed.

**Note:** Pet avoidance is only available when using the lens provided with the detector.

This nuisance protection has not been verified by Underwriter's Laboratories, Inc.

© 1997 Radionics, Inc., Salinas, CA, U.S.A. All rights reserved.

™ The Radionics logo is a registered trademark of Radionics, Inc., Salinas, CA, U.S.A.



**Radionics™**

Radionics, Inc., 1800 Abbott Street  
Salinas, CA, 93901, U.S.A.  
Customer Service: (800) 538-5807